

- LENGTH OPTIONS
- 6' BENCH
  - 8' BENCH

- NOTES
- 1.) ALL STL MEMBERS COATED W/ ZINC RICH EPOXY THEN FINISHED W/ POLYESTER POWDER COATING.
  - 2.) 1/2" X 3 3/4" EXPANSION ANCHOR BOLTS PROVIDED.
  - 3.) CUSTOM LETTERING AVAILABLE FOR RECESSED SIDE PANELS ( TOTAL OF 37 SPACES ).

CUSTOM LETTERING ( 37 SPACES ) \_\_\_\_\_

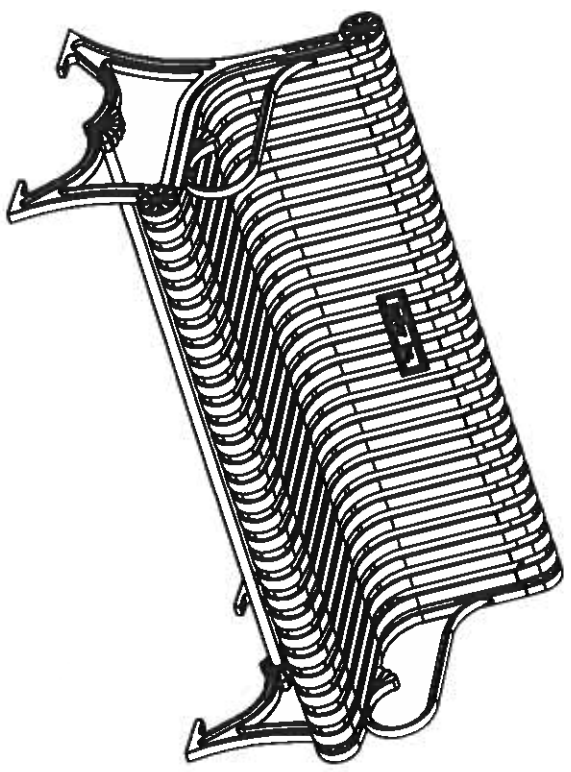

**Duker, Inc.**

BENCH

DATE DRAWN : 11/19/02  
 DRAWN BY : CDC  
 DATE REV. : 00/00/00  
 REV. BY : XXX

REV. A

DRAWING NUMBER

58 SERIES 001  
 FOR 2" X 10" PLAQUE

SHEET 1 OF 2

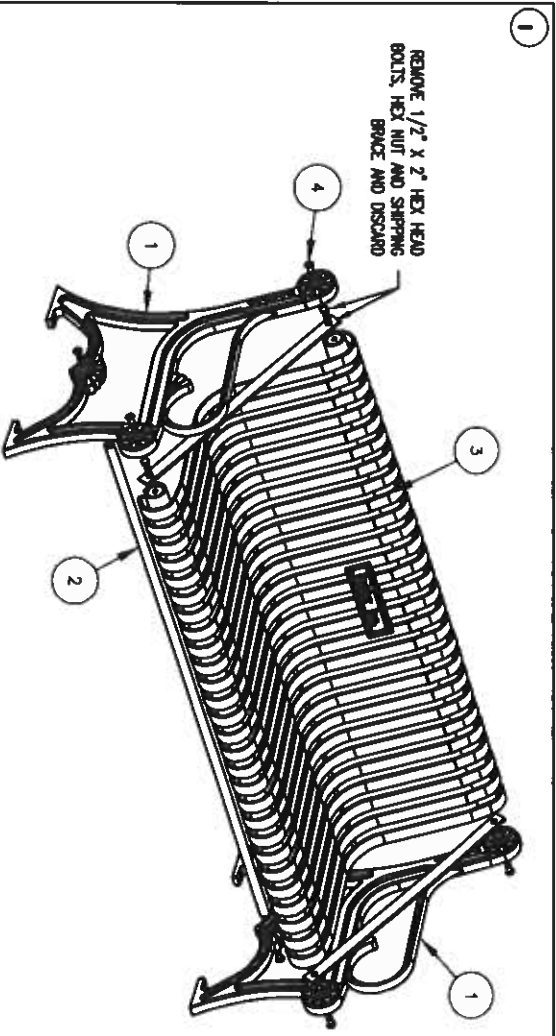

REMOVE 1/2" X 2" HEX HEAD BOLTS, HEX NUT AND SHIPPING BRACE AND DISCARD

**PARTS LIST**

ITEM	QTY	PART NO	DESCRIPTION
1	2	0-57-00-02	CAST IRON BENCH SUPPORT W/BRCK
2	1	0-57-60-04	71 3/4" PIPE BRACE
3	1	0-58-60-001-01	6 STL SEAT FOR ZV10 PLQ
4	6	1-12-065	1/2" X 2 1/2" FLT SRT HD CAP SCR

**KITS PROVIDED**

ITEM	QTY	PART NO	DESCRIPTION
5	1	K-ANCHOR0-4	1/2" X 3 3/4" SS ANCHOR KIT (4PC)
6	1	K-TOOL040-6	1/2" CAP HARDWARE KIT (6PC)

**NOTES:**

- 1.) DURING ASSEMBLY PROCEDURE: DO NOT COMPLETELY TIGHTEN HARDWARE.
- 2.) THE ACTUAL PARTS WILL NOT BE NUMBERED. NUMBERS ONLY APPLY TO DRAWING.
- 3.) UPON COMPLETION OF ASSEMBLY SQUARE ALL COMPONENTS THEN TIGHTEN ALL HARDWARE.
- 4.) MOUNT AND ANCHOR AS SPECIFIED.

**TOOLS REQ'D**

- 3/4" WRENCH
- 5/16" ALLEN WRENCH
- 1/2" MASONRY DRILL BIT
- DRILL
- RATCHET STRAP (PROVIDED)



1A

PLACE SEAT ASSEMBLY ON WORK SURFACE ALLOWING ACCESS TO END THEN PLACE RATCHET STRAP AROUND SEAT ASSEMBLY AS SHOWN ABOVE.



1B

TIGHTEN STRAP UNTIL SHIPPING BRACKET BECOMES LOOSE. THEN REMOVE AND DISCARD BOLTS & SHIPPING BRACKET.



1C

ATTACH CASTING TO SEAT ASSEMBLY USING 1/2" X 2 1/2" FLAT SOCKET HEAD CAP SCREWS. IF HOLES IN CASTING DO NOT ALIGN WITH THE SEAT ASSEMBLY, ADJUST BY USING THE RATCHET STRAP.



1D

TIGHTEN HARDWARE THEN REMOVE RATCHET STRAP AND REPEAT THIS PROCEDURE ON THE OTHER END OF BENCH.

**DUMOR, inc.**

**ASSEMBLY INSTRUCTIONS**

DATE DRAWN :	10/20/08
DRAWN BY :	ESS
DATE REV. :	00/00/00
REV. BY :	XXX

REV. **A**

58 SERIES 001  
FOR 2" X 10" PLAQUE

## **GUIDELINES FOR PLAQUES**

(Using our standard Georgia Font {font size .313})

### **10" LENGTH PLAQUE**

56 LETTERS WITH UPPERCASE & LOWER CASE *PER LINE*

48 LETTERS WITH ALL UPPERCASE *PER LINE*

60 LETTERS WITH ALL LOWER CASE *PER LINE*

**\*\*\* THIS INCLUDES SPACES!!**

### **12" LENGTH PLAQUE**

61 LETTERS WITH UPPERCASE & LOWER CASE *PER LINE*

52 LETTERS WITH ALL UPPERCASE *PER LINE*

65 LETTERS WITH ALL LOWERCASE *PER LINE*

**\*\*\* THIS INCLUDES SPACES!!**

2" HIGH PLAQUE -       MAXIMUM LINES: 4  
2 1/2" HIGH PLAQUE -    MAXIMUM LINES: 6  
3" HIGH PLAQUE -        MAXIMUM LINES: 8  
3 1/2" HIGH PLAQUE -    MAXIMUM LINES: 10

MINIMUM HEIGHT OF LOWER CASE 5/32"

### **BOLD TYPE (BY APPROVAL ONLY)**

**BLACK & WHITE** Camera Ready Art Work

Can Use PDF Files (**EPS Files Are Preferred**)

No Fuzzy Art Work

All Lines Must Be At Least 2 Points Thick, 72 Points per Inch

Everything Raised On Plaque Should Be In Black on Drawing

**NO SHADING!!!**

ABOVE INFORMATION IS USING TEXT ONLY ON PLAQUE LAYOUTS.

IF GRAPHICS ARE USED, ALL GUIDELINES WILL BE VOID AND WILL BE CALCULATED ACCORDING TO GRAPHIC SIZE.